



Model 22 Piezoelectric accelerometer

Features

- **NEW!** 22-R available as replacement sensor
- World's smallest accelerometer
- Extremely light weight (0.14 gm)
- Adhesive mounting
- Ground isolated
- Scale model, circuit board, disk drive testing



Description

The Endevco® model 22 Picomin™ is the world's smallest piezoelectric accelerometer, designed specifically for vibration measurement on small objects such as scaled models, circuit boards, and disk drives. Its light weight (0.14 gm) effectively eliminates mass loading effects. The transducer is designed to have reverse polarity with respect to acceleration going into the mounting base. The accelerometer is a self-generating device that requires no external power source for operation.

The model 22 features Endevco's Piezite® type P-8 crystal element, operating in radial shear mode, which exhibits excellent output sensitivity stability over time. Signal ground is isolated from the mounting surface of the unit by a hard anodized surface. Specially designed low-noise coaxial cable is supplied for error-free operation. A tool is included in the shipping case to ensure proper removal of the cable and transducer in the field.

Endevco signal conditioner models 133, 2775B or OASIS 2000 computer-controlled system are recommended for use with this high impedance accelerometer.

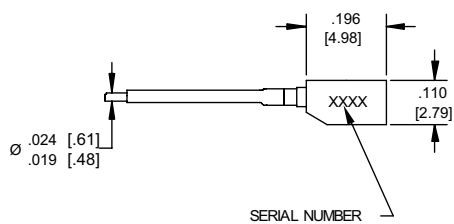
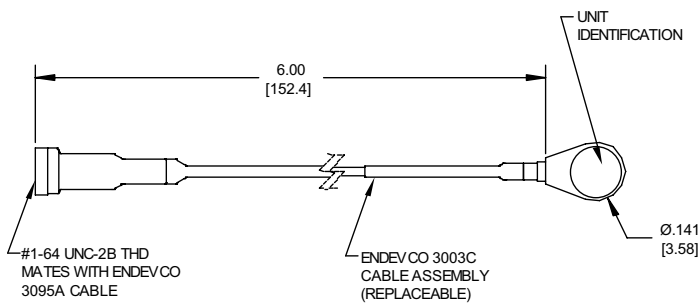

STANDARD TOLERANCE
 INCHES [MILLIMETERS]
 .XX = ± .50 [.X = ± 12.7]
 .XXX = ± .010 [.XX = ± .25]

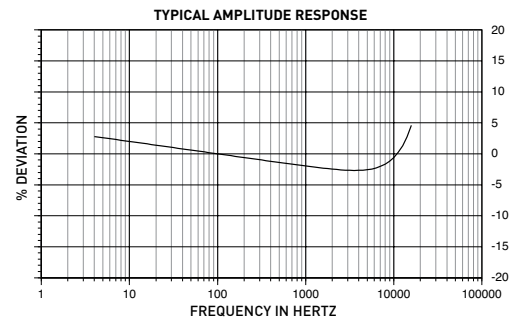
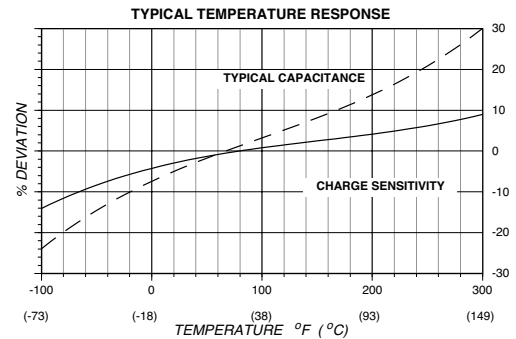

Model 22 Piezoelectric accelerometer

MEGGITT
smart engineering for
extreme environments

Specifications

The following performance specifications conform to ISA-RP-37.2 (1964) and are typical values, referenced at +75°F (+24°C), 4 mA and 100 Hz, unless otherwise noted. Calibration data, traceable to National Institute of Standards and Technology (NIST), is supplied

Dynamic characteristics

	Units	
Charge sensitivity		
Typical	pC/g	0.40
Minimum	pC/g	0.30
Frequency response		See typical amplitude response
Resonance frequency	kHz	54
Amplitude response [1]		
±5%	Hz	5 to 10 000
±1 dB	Hz	3 to 12 000
Temperature response		See typical curve
Transverse sensitivity	%	≤5
Amplitude linearity		
To 500g	%	1
500 g to 4000 g	% per 200 g	1

Electrical characteristics

Output polarity		Acceleration directed into the base of the unit produces negative output
Resistance	GΩ	≥10
Resistance at 300°F	GΩ	≥1
Isolation	GΩ	≥1
Capacitance	pF	290
Including 6 inch model 3003C		
Grounding		Signal ground isolated from mounting surface

Environmental characteristics

Temperature range		-100°F to +300°F [-73°C to +149°C]
Humidity		Epoxy sealed, non-hermetic
Shock limit [2] [3]	g pk	10 000
Base strain sensitivity	equiv. g/μ strain	0.008
Electromagnetic sensitivity	equiv. g rms/gauss	0.0009

Physical characteristics

Dimensions		See outline drawing
Weight		
Unit only	gm [oz]	0.14 [0.005]
Unit with cable	gm [oz]	0.4 [0.014]
Case material		Aluminum alloy, hard anodized
Cable description [4]		0.019/.024 diameter PFA insulated coaxial cable, 0.003 diameter center conductor, Teflon PFA dielectric Adhesive
Mounting [5]		

Calibration

Supplied:		
Charge sensitivity	pC/g	
Capacitance including 6 inch replaceable cable	pF	
Capacitance cable	pF	
Transverse sensitivity	%	
Charge frequency response	%	20 Hz to 10 kHz

Accessories

Product	Description	22	22-R
32041	Removal wrench	Included	Optional
3095A-120	Cable assembly, 10 ft	Included	Optional
3003C	Cable assembly, attached	Included	Included
32279	Mounting wax	Included	Optional
133	Signal conditioner	Optional	Optional
2775B	Signal conditioner	Optional	Optional
4990A-1	OASIS 2000 computer-controlled system	Optional	Optional

Notes:

- Low-end response of the transducer is a function of its associated electronics.
- When exposed to high g, and large displacement, the cables must be tied down as close to the accelerometer as possible to prevent cable whip and subsequent cable failure.

- Short duration shock pulses, such as those generated by metal-to-metal impacts, may excite transducer resonance and cause linearity errors. Send for TP290 for more details.
- See instruction manual before removing cable assembly.
- Depending on the dynamic and environmental requirements, adhesives such as petro-wax, hot-melt glue, and cyanoacrylate epoxy (super glue) may be used to mount the accelerometer temporarily to the test structure. An adhesive mounting kit (P/N 31849) is available as an option from Endeveco. Remove epoxy-mounted accelerometers by first softening the epoxy with an appropriate solvent, then twist the unit off with the supplied removal tool. Failure to heed this caution may cause permanent damage to the transducer, which is not covered under warranty.
- Maintain high levels of precision and accuracy using Endeveco's factory calibration services. Call Endeveco's inside sales force at 800-982-6732 for recommended intervals, pricing and turn-around time for these services as well as for quotations on our standard products.



Continued product improvement necessitates that Endeveco reserve the right to modify these specifications without notice. Endeveco maintains a program of constant surveillance over all products to ensure a high level of reliability. This program includes attention to reliability factors during product design, the support of stringent Quality Control requirements, and compulsory corrective action procedures. These measures, together with conservative specifications have made the name Endeveco synonymous with reliability.