



# 8510B -1, -2, -5 Piezoresistive pressure transducer

## Features

- 1, 2 and 5 psig ranges
- 300 mV full scale
- Rugged, miniature



## Description

The Endevco model 8510B is a rugged, miniature, high sensitivity piezoresistive pressure transducer. It has a 10-32 mounting thread, 0.15 inch (3.8 mm) face diameter and is available in ranges from 1 psi to 2000 psi. Low pressure ranges are shown on this sheet. Its high sensitivity combined with high resonance makes it ideal for measuring dynamic pressure.

Endevco pressure transducers feature a four active arm strain gage bridge diffused into a unique sculptured silicon diaphragm for maximum sensitivity and wideband frequency response. Self-contained hybrid temperature compensation provides stable performance over the temperature range of 0°F to 200°F (-18°C to +93°C). Endevco transducers also feature excellent linearity (even to 3X range), high shock resistance, and negligible sensitivity to temperature transients.

The model 8510B is designed for a wide variety of aerospace, automotive and industrial measurements which require a combination of small size, high sensitivity, and wideband frequency response. Its vent tube may be connected to a standard reference manifold or used for differential pressure measurements.

The model 8510B is available with metric M5 x 0.8 mounting thread as 8510B-XM5 on special order.

**Recommended electronics for signal conditioning and power supply are the Endevco model 126 and 136 general purpose three channel conditioners, ultra low noise 4430A conditioner, or the 4990A-X (Oasis) multi-channel rack mount system.**

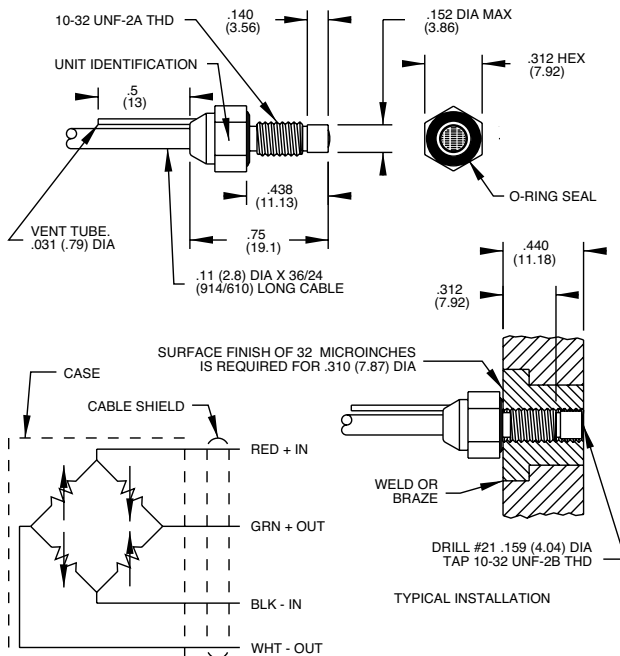

STANDARD TOLERANCE  
 INCHES (MILLIMETERS)  
 .XX = +/- .03 (X = +/- .8)  
 .XXX = +/- .010 (XX = +/- .25)

# 8510B -1, -2, -5

## Piezoresistive pressure transducer

**MEGGITT**  
smart engineering for  
extreme environments

### Specifications

The following performance specifications conform to ISA-RP-37.2 (1964) and are typical values, referenced at +75°F (+24°C), 100 Hz and 10 Vdc unless otherwise noted. Calibration data, traceable to National Institute of Standards and Technology (NIST), is supplied.

Dynamic characteristics	Units	-1	-2	-5
Range [1]	psig	0-1	0-2	0-5
Positive sensitivity [2]	mV/psi	200 ±50	100 ±55/-25	60 ±20
Combined: non-linearity, non-repeatability, pressure hysteresis [3]	% FSO RSS max	1.50	1.50	0.75
Non-linearity, independent	% FSO typ	1.0	1.0	0.5
Non-repeatability	% FSO typ	0.2	0.2	0.1
Pressure hysteresis	% FSO typ	0.2	0.2	0.1
Zero measurand output [4]	mV max	±10	±10	±10
Zero shift after 3X range	±% 3X FSO max	0.2	0.2	0.2
Thermal zero shift				
from 0°F to +200°F (-18°C to +93°C)	±% FSO max	3	3	3
Thermal sensitivity shift				
from 0°F and +200°F (-18°C to +93°C)	±% max	4	4	4
Resonance frequency	Hz	55 000	70 000	85 000
Non-linearity at 3X range	% 3X FSO	2.5	2.5	2.0
Thermal transient response per	psi/°F	0.003	0.003	0.003
ISA-S37.10, para. 6.7, procedure I	psi/°C	0.005	0.005	0.005
Photoflash response [5]	Equiv. psi	0.2	0.3	0.7
Warm-up time [6]	ms	1	1	1
Acceleration sensitivity	Equiv. psi/g	0.0002	0.0002	0.0002
Burst pressure (diaphragm/reference side) [7]	psi min	25/25	40/40	100/100

### Electrical

Full scale output	300 ±100 mV at 10.0 Vdc; 200 ±50 mV at 10.0 Vdc for 8510B-1
Supply voltage [8]	10.0 Vdc recommended, 18.0 Vdc maximum
Electrical configuration	Active four-arm piezoresistive bridge
Polarity	Positive output for increasing pressure into (+) port (end with screen on it)
Resistance	
Input	2000 ±800 ohms
Output	1600 ±600 ohms
Isolation	100 megohms minimum at 50 volts; leads to case, leads to shield, shield to case
Noise	5 microvolts rms typical, dc to 50 000 Hz; 50 microvolts rms maximum, dc to 50 000 Hz

### Mechanical

Case material	Stainless steel (17-4 PH CRES)
Cable, integral	4 conductor No. 32 AWG Teflon® insulated leads, braided shield, silicone jacket, 30 ±3 in (760 ±76 mm)
Dead volume (+) port	0.0003 cubic inches (0.005 cc)
Mounting torque	10-32 UNF-2A threaded case 0.438 inch (11.12 mm) long/15 ±5 lbf-in (1.7 ±0.6 Nm)
Weight	2.3 grams (cable weighs 9 grams/meter)

### Environmental characteristics

Media [9] [10]	
Temperature [9] [10]	-65°F to +250°F (-54°C to +121°C)
Vibration	1000 g pk
Acceleration	1000 g
Shock	20 000 g, 100 microsecond haversine pulse
Humidity	Isolation resistance greater than 100 megohms at 50 volts when tested per MIL-STD-202E, method 103B, test condition B

# 8510B -1, -2, -5 Piezoresistive pressure transducer

**MEGGITT**  
smart engineering for  
extreme environments

## Calibration data supplied

Data supplied for all parameters in Certified Performance section. Optional calibrations available for all parameters in Typical Performance section.

### Included accessories

EHR93 O-ring, Viton

### Optional accessories

EHR96 O-ring, fluorosilicone  
24328-3 4 conductor shielded cable

### Notes:

1. Pressure ranges can be considered bidirectional, e.g. an 8510B-5 can be used to measure + or -5 psig. Sensitivity in the positive direction is typically within 1% of sensitivity in the negative direction. Sensitivity calibration provided with each unit is for positive direction.
2. 1 psi = 6.895 kPa = 0.069 bar.
3. FSO (Full Scale Output) is defined as transducer output change from 0 psig to + full scale pressure. Calibration provided is for positive pressure. Sensitivity to negative pressures is typically within 1% of positive pressure sensitivity.
4. Zero Measurand Output (ZMO) is the transducer output with 0 psig applied.
5. Per ISA-S37.10, Para. 6.7, Proc. I. The metal screen partially shields the silicon diaphragm from incident radiation. Accordingly, light incident at acute angles to the screen generally increases the error by a factor of 2 or 3.
6. Warm-up time is defined as elapsed time from excitation voltage "turn on" until the transducer output is within  $\pm 1\%$  of reading accuracy.
7. Reference side pressure may be 300 psi on all ranges if differential limits (psid) are not exceeded.
8. Use of excitation voltages other than 10.0 Vdc requires manufacture and calibration at that voltage since thermal errors increase with high excitation voltages.
9. Internal seals are epoxy and are compatible with clean dry gas media. Media in (+) measurand port is exposed to CRES, nickel-iron alloy, Parylene C, epoxy, and the Viton® O-ring media in (-) measurand port is exposed to the above and RTV silicone coating. For use in water or corrosive media, contact the factory for modifications and installation precautions which may be taken to extend service life.
10. O-Ring, Endevco part number EHR93 Viton® is supplied unless otherwise specified on Purchase Order. Part number EHR96 Parker material L677-70 for leak tight operation below 0°F (-18°C) is available on special order.
11. Maintain high levels of precision and accuracy using Endevco's factory calibration services. Call Endevco's inside sales force at 800-982-6732 for recommended intervals, pricing and turnaround time for these services as well as for quotations on our standard products.

NOTE: Tighter specifications are available on special order.



Continued product improvement necessitates that Endevco reserve the right to modify these specifications without notice. Endevco maintains a program of constant surveillance over all products to ensure a high level of reliability. This program includes attention to reliability factors during product design, the support of stringent Quality Control requirements, and compulsory corrective action procedures. These measures, together with conservative specifications have made the name Endevco synonymous with reliability.

©ENDEVCO CORPORATION. ALL RIGHTS RESERVED 30700 RANCHO VIEJO ROAD, SAN JUAN CAPISTRANO, CA92675 USA  
(800) 982-6732 • (949) 493-8181 fax (949) 661-7231 • www.endevco.com • Email: applications@endevco.com

072910